

From Potential to Practicality:

Feasibility and Barriers of Seasonal Thermal Energy Storage for Dutch District Heating

Prof. dr. ir. Mina Shahi,
Chair of Thermal Conversion and Storage
University of Twente
m.shahi@utwente.nl



UNIVERSITY OF TWENTE.

Case study of District Heating Systems (DHs) in Enschede area

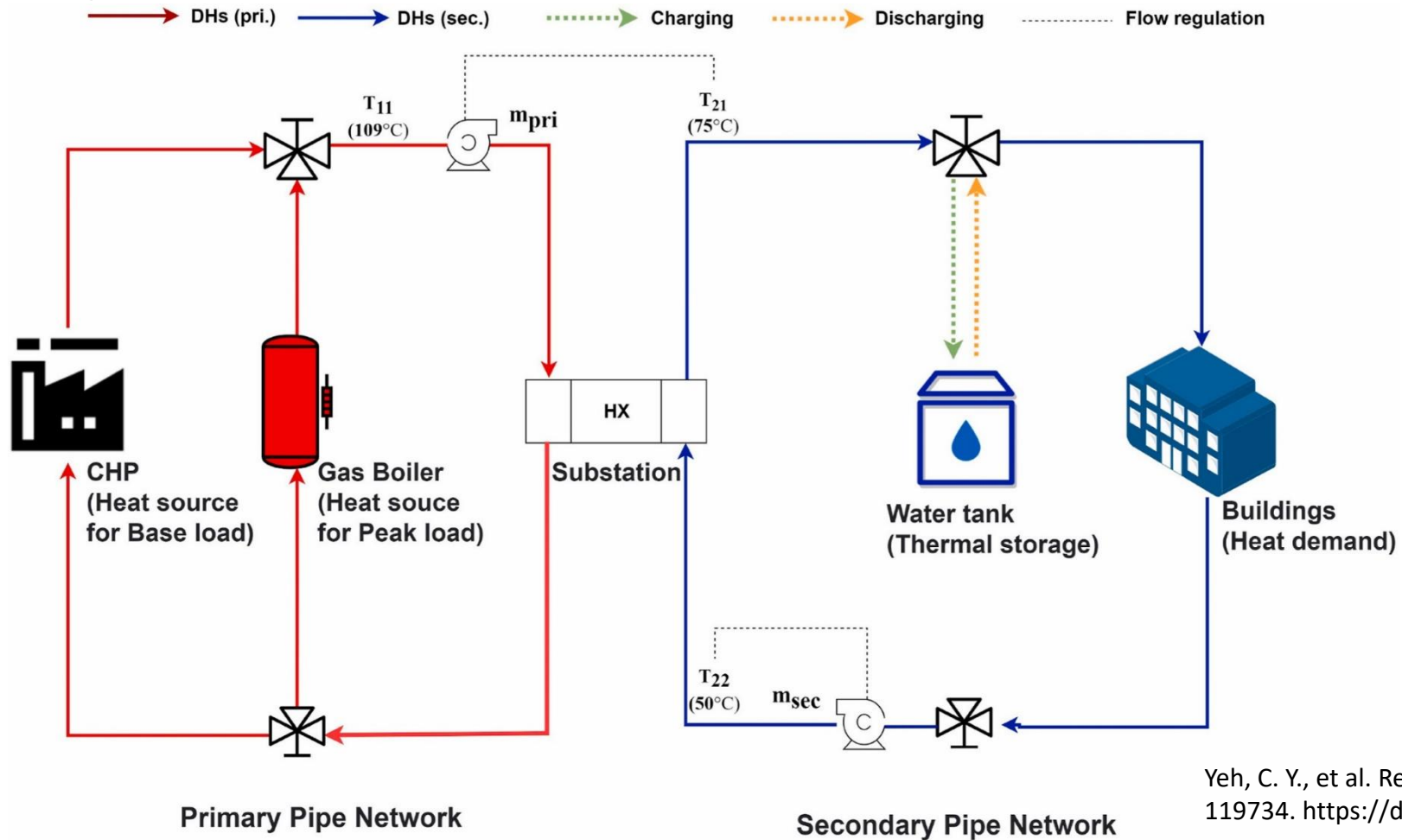

Yeh, C. Y., et al. Renewable energy, 221, Article 119734. <https://doi.org/10.1016/j.renene.2023.119734>

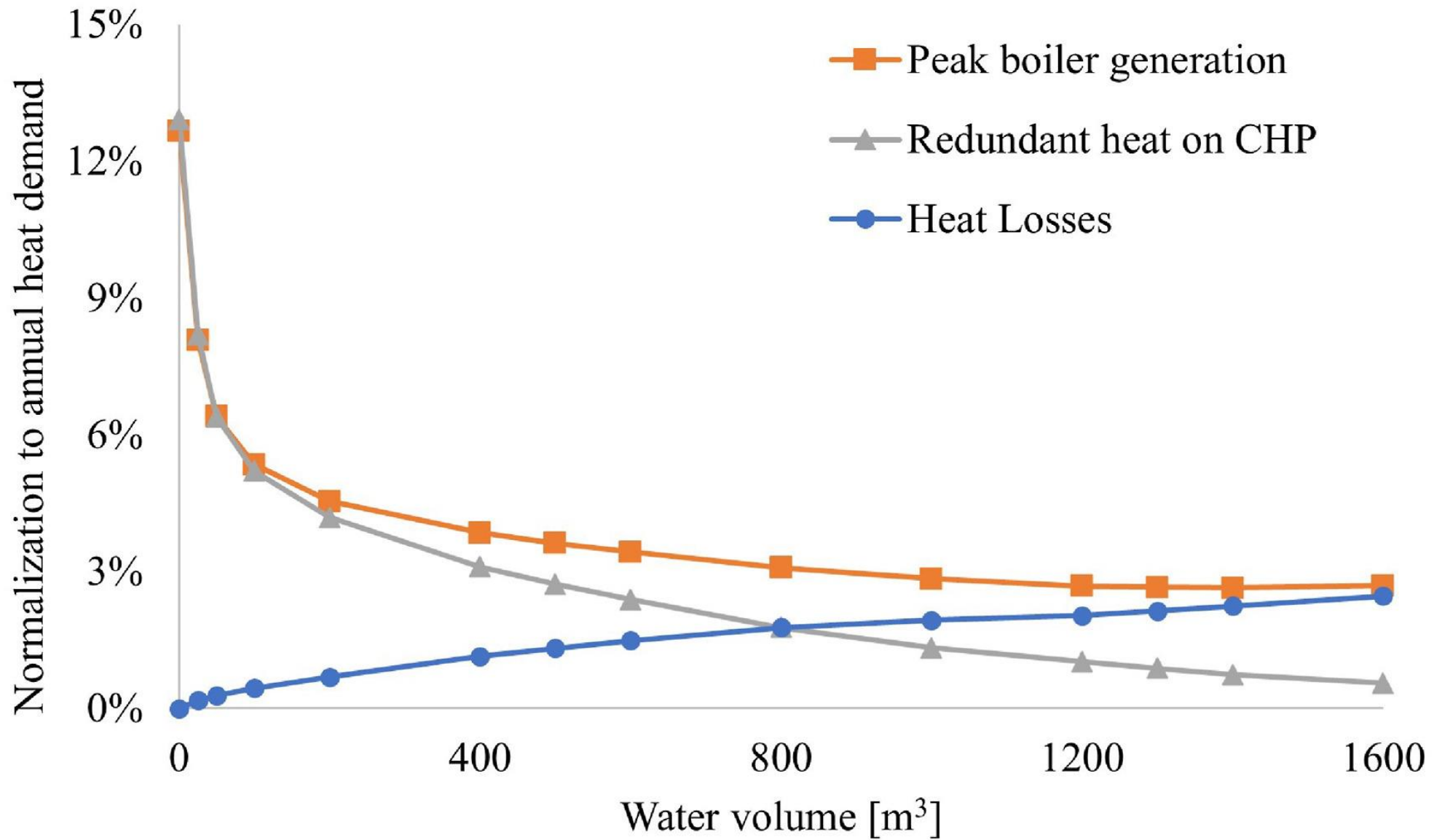

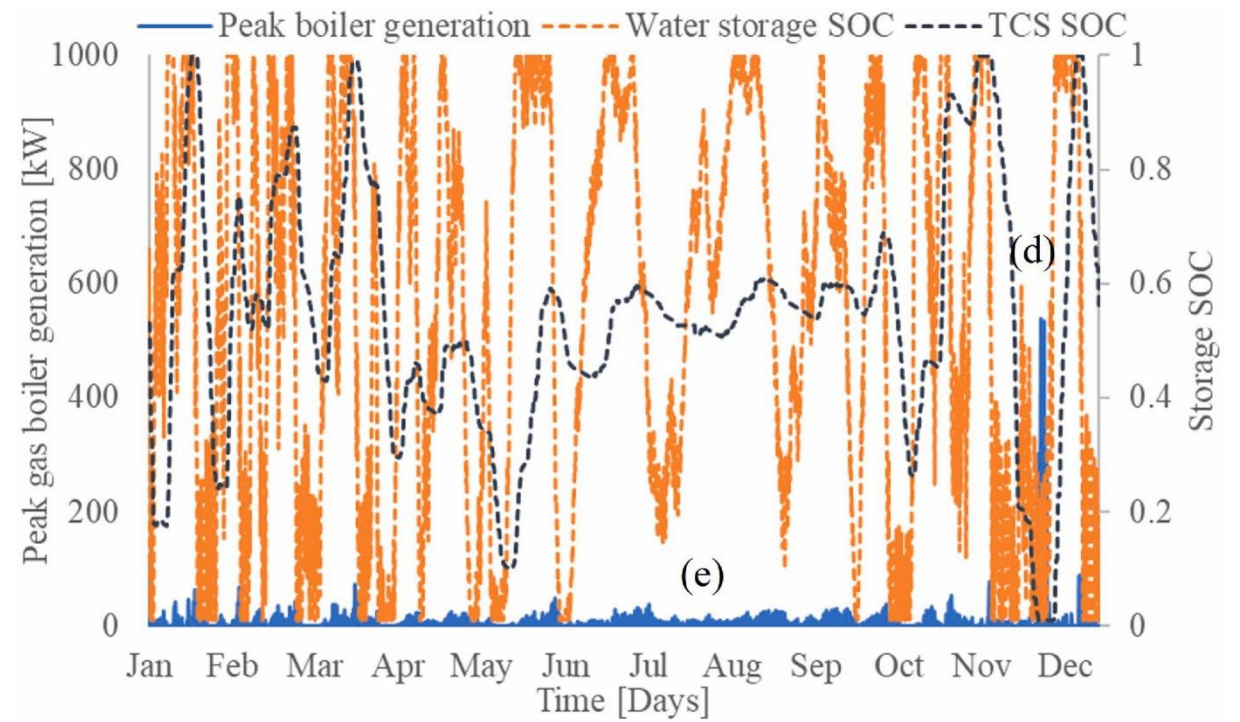
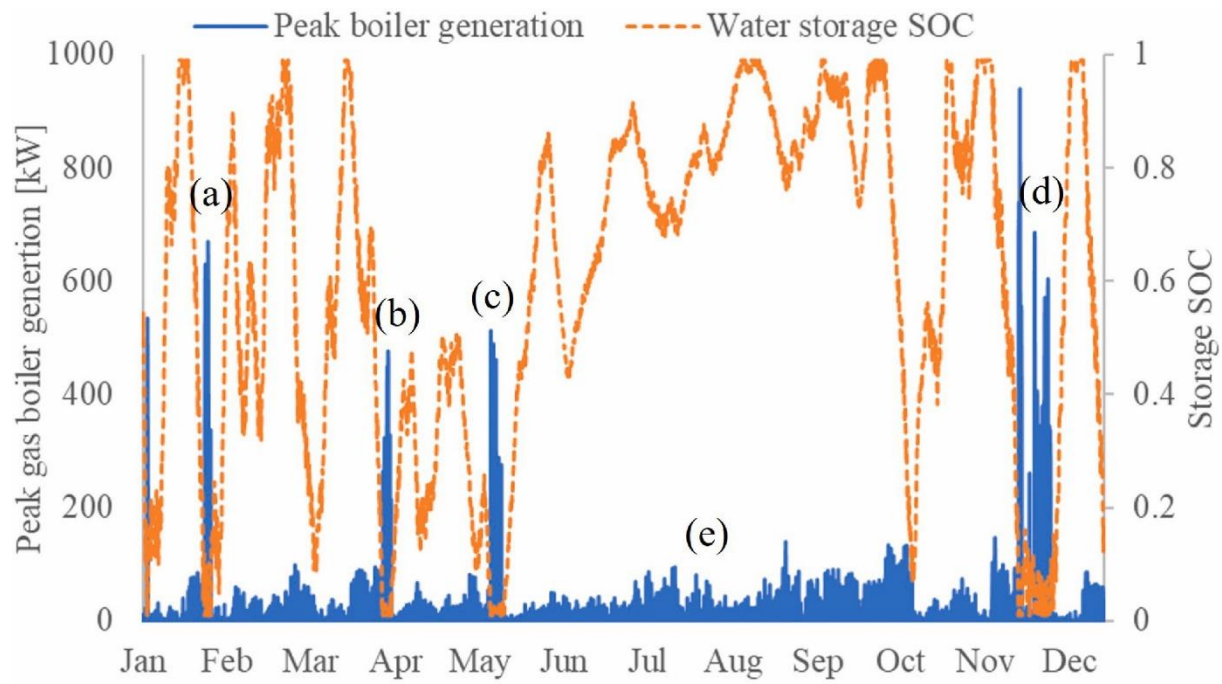

Yeh, C. Y., et al. Renewable energy, 221, Article 119734. <https://doi.org/10.1016/j.renene.2023.119734>

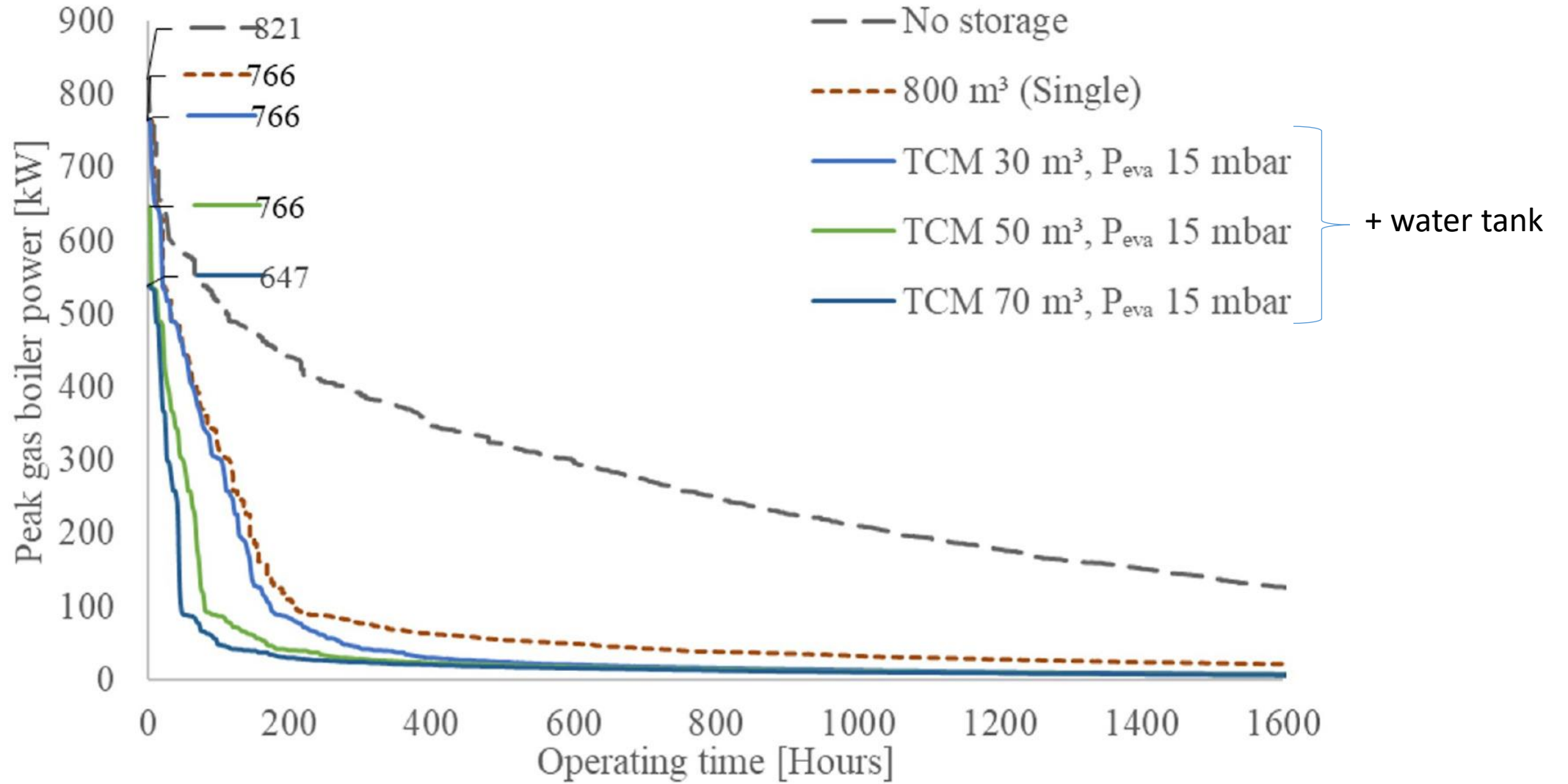

Yeh, C. Y., et al. Renewable energy, 221, Article 119734. <https://doi.org/10.1016/j.renene.2023.119734>

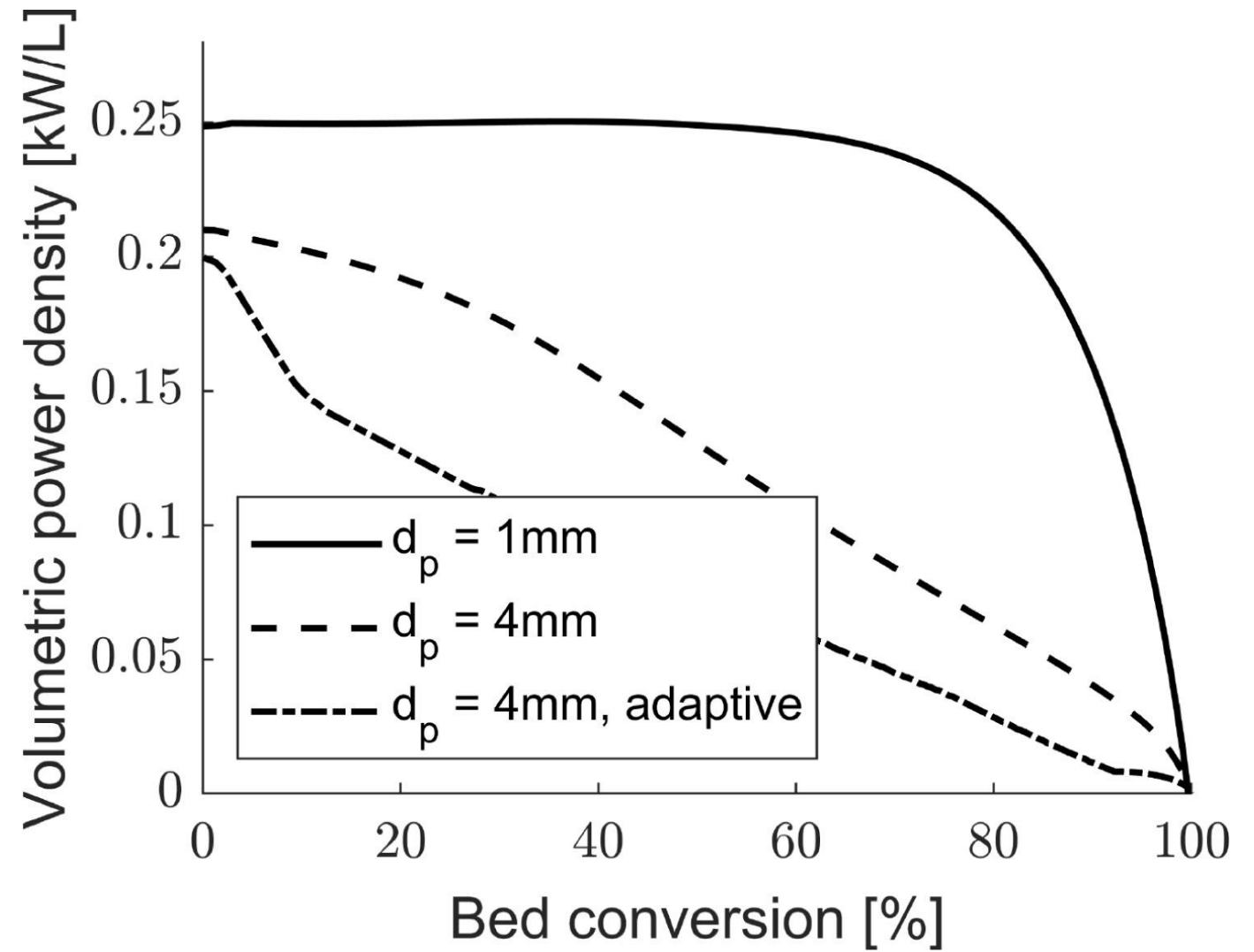
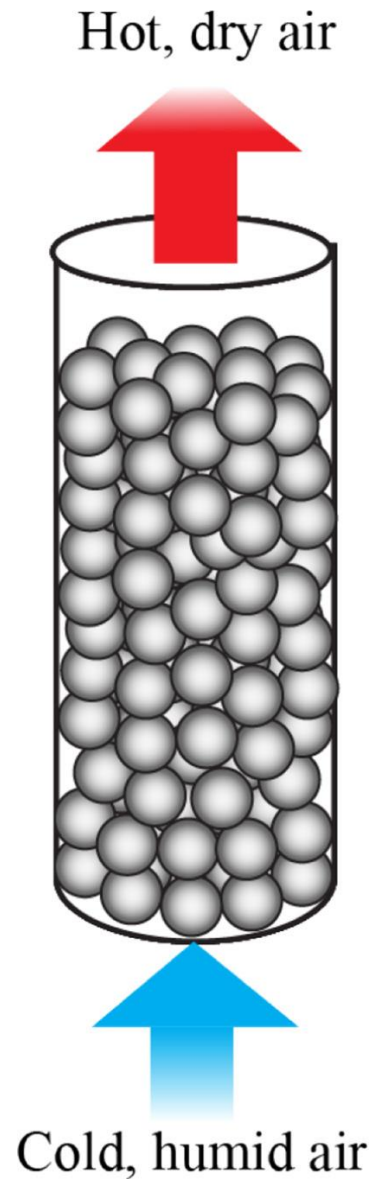

Kieskamp, B. et al. *Journal of Energy Storage*, 78, Article 110028.

Process

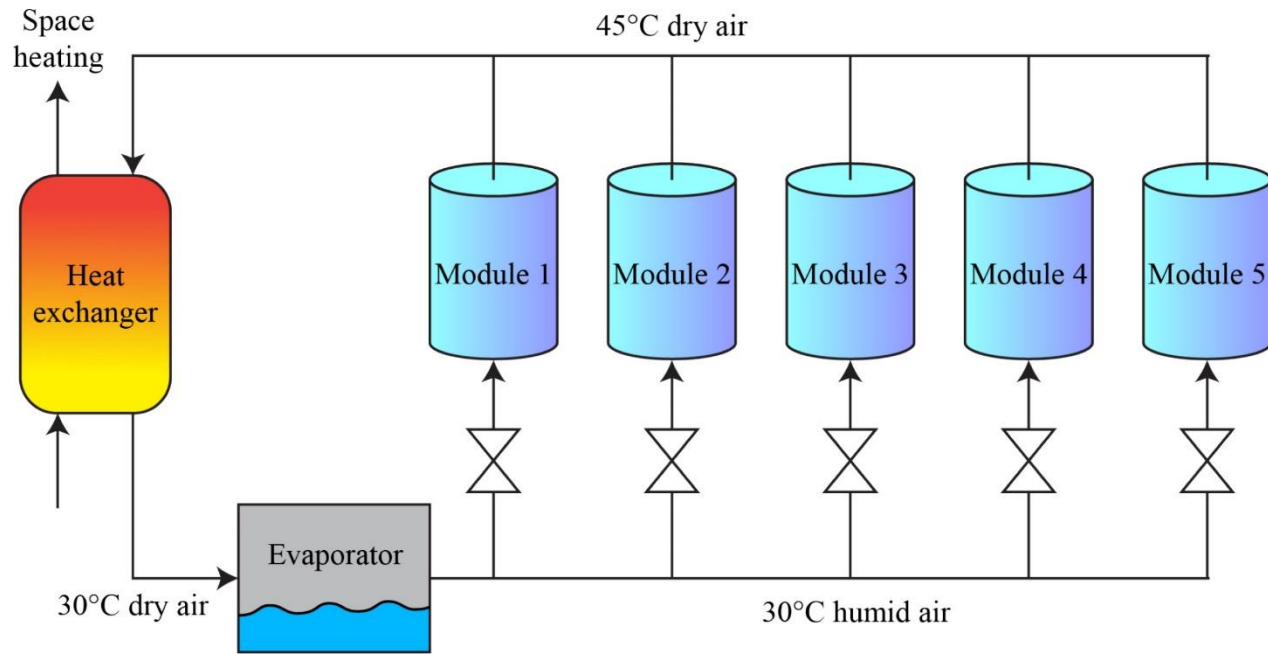

Kieskamp, B. et al. *Journal of Energy Storage*, 78, Article 110028.

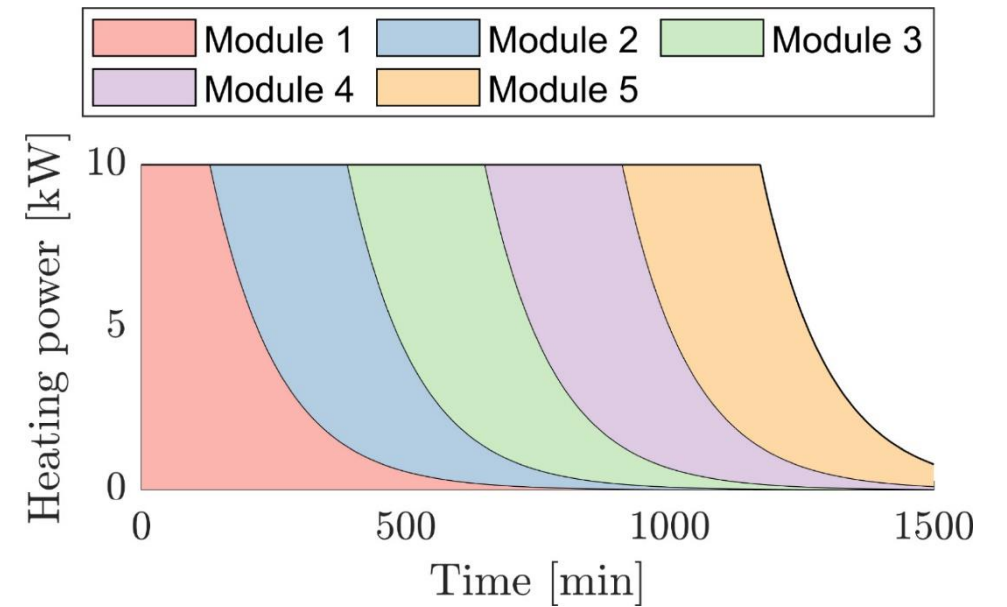

Component

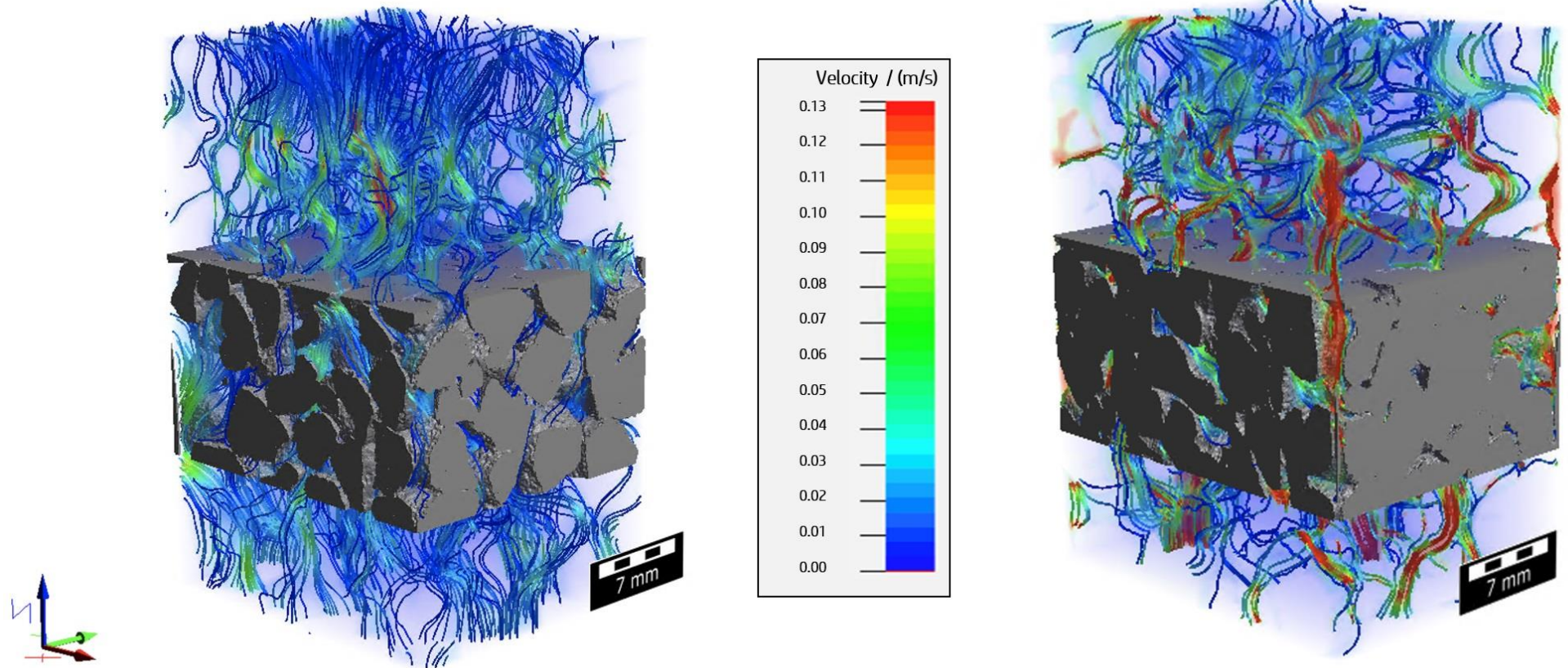

Permeability	Uncycled Packed Bed	Cycled Packed Bed
K_{zz}	8.64	5.23

A. Arya et al. Journal of Nondestructive Evaluation
<https://doi.org/10.1007/s10921-024-01092-7>

Decarbonize
Heating and Cooling

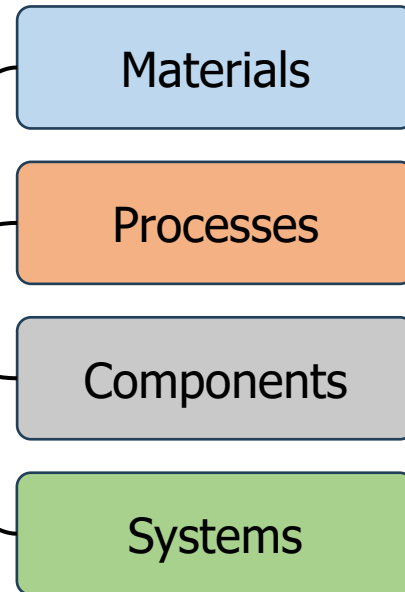
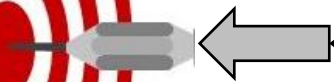

Thank You!

Amir Mahmoudi, Abhishek Purandare, Khuram Walayat, Aastha Arya,
Chung-Yu Yeh, Bram Kieskam, Zeynep Uykun, Bart van der Vaart, Sergio
Cruz Lopez, Kevin Lindeboom