

Modeling and Predictive Control for Large-Scale District Heating Networks: Challenges & Opportunities

Mohammad Khosravi



Delft Center for
Systems and Control

Delft Center for Systems and Control

Delft University of Technology

Swiss Symposium of Thermal Energy Storage

January 24th, 2025

- Assistant Professor
Delft Center for Systems & Control, TU Delft



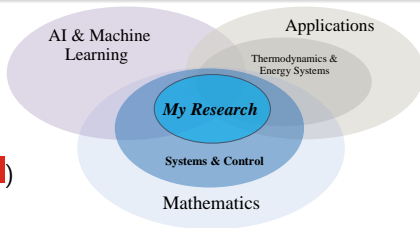

- Systems & Control (BSc , MSc , PhD )
- Mathematics (BSc , MSc )



My research:

 **Theory:** $\{Statistical\ Learning\ Theory\} \cap \{Systems\ \&\ Control\}$

 reliable and efficient data-driven techniques

 **Application:** Smart & Safe Efficient Energy Systems  net-zero CO₂ emission

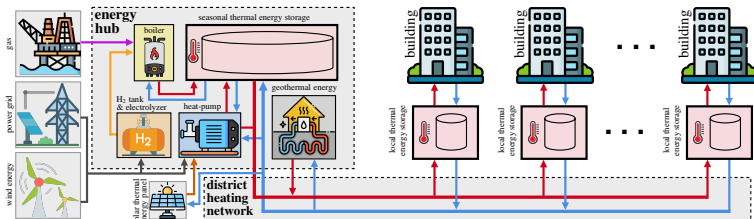

What is a District Heating Network?

- **District Heating Network (DHN):** A large-scale network of insulated pipes,
 - ◊ connecting various entities and ancillary devices,
 - ◊ to **distribute** heating and cooling energy
 - ◊ between **producers**, **storage systems**, and **consumers**
 - ◊ through the circulation of **thermal fluids**.

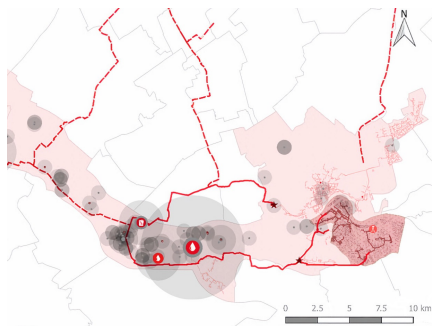

Rotterdam DHN supplied with industrial waste heat

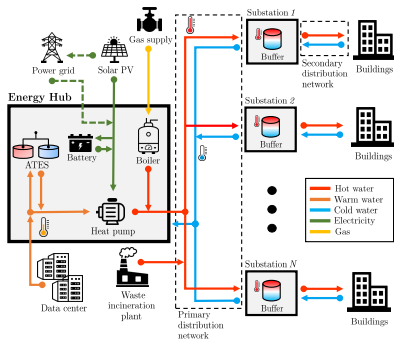

DHN & connected entities

- DHN has **dynamic behavior** and **thermal inertial**, exhibiting **thermal storage** effects and behaviors.

Future District Heating Networks: Opportunities & Challenges

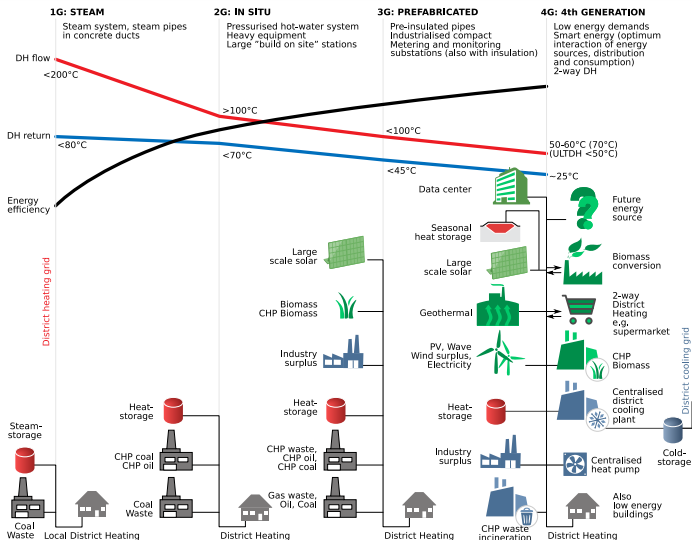

- Trend in the developments of DHN: Generation 4+

- Connection of **numerous new entities** & urge of **decentralization**
- Major improvement in **energy efficiency** & need of **smart energy management schemes**

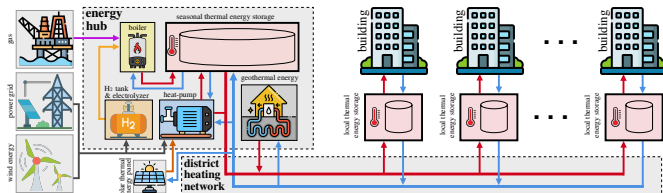

- **Objective:** Designing a smart energy management system for DHN with
 - support for **bidirectional** heating and cooling supply
 - integration of **multiple** decentralized district heating and cooling generation
 - maximum efficiency by **minimizing thermal losses** via tight demand tracking
 - establishing the foundation for a **thermal energy market**
 - **modular expansion** capability
 - ...

- **Solution:**
Advanced Model Predictive Control (MPC)

- **Suitable model**
- Suitable optimization heuristic and solver

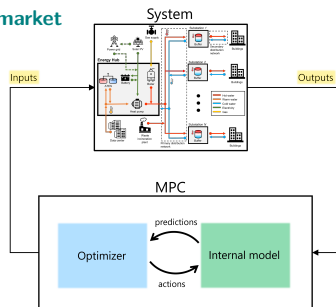

- What is the model of a DHN as a **controlled dynamical system**?
- Based on the one-dimensional incompressible Euler equations, each **pipe** in the DHN is represented by a nonlinear PDE as

$$\text{Momentum:} \quad J \partial_t q + \partial_x p + \frac{8K\rho}{\pi^2 d^5} |q|q = 0,$$

$$\text{Advection:} \quad \Phi \partial_t T + q \partial_x T + \frac{4U\Phi}{\rho c_p d} (T - T_a) = 0,$$

where

- p denotes the flow pressure,
 - q indicates the flow rate, and,
 - T is the flow temperature
-
- The dynamics of **heat-exchangers**, **heat-pumps**, and **thermal storages** are similarly governed by **PDEs of thermodynamics**.
 - The distribution network dynamics are
 - **infinite-dimensional** equations (PDEs)
 - a **large-scale** system of **coupled** equations (network)
 - highly **nonlinear** in nature (friction & cross terms)
 - separation across **multiple time scales** (thermal vs. hydraulics)

- The distribution network dynamics are
 - **infinite-dimensional** equations (PDEs)
 - a **large-scale** system of **coupled** equations (network)
 - highly **nonlinear** in nature (friction & cross terms)
 - separation across **multiple time scales** (thermal vs. hydraulics)
- The main challenges:
 - **modeling-for-control?**
 - **tractable MPC formulation?**
- We provide detailed solution to these issues in
 - M. Sibeijn, S. Ahmed, M. Khosravi, and T. Keviczky, "*Economic Nonlinear Model Predictive Control of Prosumer District Heating Networks*", IEEE TCST, **2025** (to appear).
 - M. Sibeijn, M. Khosravi, and T. Keviczky, "*Mitigating short-sightedness of MPC for district heating networks using dual dynamic programming*", CDC **2024**.
 - M. Sibeijn, S. Ahmed, M. Khosravi, and T. Keviczky, "*Dissipativity analysis for economic nonlinear MPC of district heating networks*", ECC **2024**.
 - ... and several other ongoing works ... 
- But, what is the outline of approach?

- Modeling highlights:

- simplification via **algebraic graph theory**
- application of **spatial discretization** (thermal nodes)
- flow dynamics vs. thermal dynamics: **fast & slow**
- **constant altitude** differences (Netherlands, Denmark, ...)

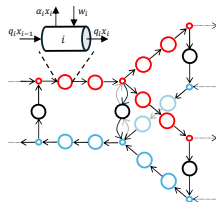

- The **thermal** network model:

$$\begin{aligned} V \dot{x}(t) &= A(q(t))x(t) + B_p e_p(t) + B_d e_d(t), \\ y(t) &= Cx(t), \end{aligned}$$

$$\begin{aligned} x(t) &\in \mathbb{R}^n, \quad q(t) \in \mathbb{R}^{n_e}, \quad e_p(t) \in \mathbb{R}^{n_u}, \\ e_d(t) &\in \mathbb{R}^{n_d}, \quad y(t) \in \mathbb{R}^{n_y}. \end{aligned}$$

- The main **hydraulic** constraints are

$$q(t) = F^T q_f(t)$$

$$q^{ij} q^{ji} = 0, \text{ if } (i, j) \in \mathcal{E} \cap -\mathcal{E}$$

$$F \underline{R}(q(t)) \odot q(t) \leq F \bar{H}$$

- We have a **systematic approach** for modeling DHNs with adaptable resolution
 - Infinite-dimension and time-scale separation issues are resolved
 - Highly accurate discretizations lead to large dimensions n
 - Dynamics remain nonlinear (**bilinear**)
- Model formulation allows **multiple producer** and **producer** configurations
- Kirchoff's loop constraints are **convexified**, although bidirectional constraints remain nonconvex

Discrete-time Optimal Control Problem

$$\begin{aligned}
 V_N(x(k)) &= \min_{x_t, u_t} \sum_{t=0}^N \ell_t(x_t, u_t) \\
 \text{s.t. } x_{t+1} &= \phi(x_t, u_t) := \begin{cases} x_{t+1}^{th} = f(x_t^{th}, x_t^j, q_t, e_{p,t}, e_{d,t}) \\ 0 = g(x_t^{th}, x_t^j, q_t, e_{p,t}, e_{d,t}) \end{cases} & \text{(DAE)} \\
 x_t &\in \mathbb{X}_t \\
 u_t &\in \mathbb{U}_t \supset \begin{cases} q_t = F^\top q_{f,t} & \text{(Ind. flows)} \\ q_t^{ij} q_t^{ji} = 0, \text{ if } (i, j) \in \mathcal{E} \cap -\mathcal{E} & \text{(Bid. flows)} \\ F\underline{R}(q_t \odot q_t) \leq F\overline{H} & \text{(K'hoff)} \end{cases} \\
 t &= \{0, \dots, N-1\} \\
 x_0 &= x(k)
 \end{aligned}$$

(DT-OCP)

- **Difference Algebraic Equations** via **Euler backward method**
- **Addressing MPC shortsightedness** with **value function approximation**
- Enhancing **MPC tractability** through **warm-starting** and **convexification**

Control policies:

- RBC: Rule-Based Control
- SP-MPC: Single-Producer + MPC
- MP-MPC: Multi-Producer + MPC
- SPS-MPC: Single-Producer model with Storage + MPC
- MPS-MPC: Multi-Producer model with Storage + MPC

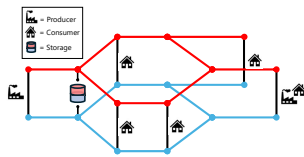

AROMA DHN Benchmark

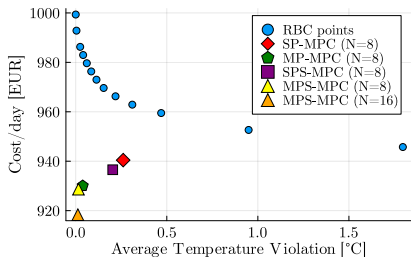

Cost versus average temperature violation; sufficient pumping capacity.

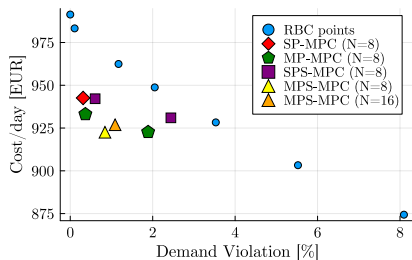

Cost versus demand violation; active pumping constraints.

Future Directions & Ongoing Research Works

- **Improving value function approximation** for DHN MPCs
- Optimal **sensor placement** and **sensor scheduling** for DHN state estimation & monitoring
- Distributed coordination for **distributed** DHN MPC
- DHN integration with **electricity grids**
- **Security, safety, and privacy**
- ...

Mohammad Khosravi

Mohammad.Khosravi@tudelft.nl

<https://www.dcsc.tudelft.nl/~mohammadkhosravi/>

- [1] I. Acheilas, F. Hooimeijer, and A. Ersoy, “*A decision support tool for implementing district heating in existing cities, focusing on using a geothermal source*”, *Energies*, 13.11, **2020**, p. 2750.
- [2] R. Krug, V. Mehrmann, and M. Schmidt, “*Nonlinear optimization of district heating networks*”, *Optimization and Engineering*, 22.2, **2021**, pp. 783–819.
- [3] A. La Bella, L. Nigro, and R. Scattolini, “*Predictive Control and Benefit Sharing in Multi-Energy Systems*”, *IEEE Transactions on Control Systems Technology*, **2023**.
- [4] H. Lund, S. Werner, R. Wiltshire, S. Svendsen, J. E. Thorsen, F. Hvelplund, and B. V. Mathiesen, “*4th Generation District Heating (4GDH): Integrating smart thermal grids into future sustainable energy systems*”, *Energy*, 68, **2014**, pp. 1–11.
- [5] S. Paardekooper, R. Sjøgaard Lund, B. Vad Mathiesen, M. Chang, U. R. Petersen, L. Grundahl, A. David, J. Dahlbæk, J. Kapetanakis, H. Lund, et al., “*Heat Roadmap Europe 4: Quantifying the Impact of Low-Carbon Heating and Cooling Roadmaps*”, **2018**.
- [6] M. Sibeijn and S. Pequito, “*Discrete-time Linear Time-invariant Distributed Minimum Energy Estimator*”, *IFAC-PapersOnLine*, 56.2, **2023**, pp. 3856–3861.
- [7] M. Sibeijn, S. Ahmed, M. Khosravi, and T. Keviczky, “*Economic Nonlinear Model Predictive Control of Prosumer District Heating Networks*”, *IEEE Transactions on Control Systems Technology*, **2025** (to appear).
- [8] M. Sibeijn, M. Khosravi, and T. Keviczky, “*Mitigating short-sightedness of MPC for district heating networks using dual dynamic programming*”, *IEEE Conference on Decision and Control (CDC)*, **2024**.
- [9] M. Sibeijn, S. Ahmed, M. Khosravi, and T. Keviczky, “*Dissipativity analysis for economic nonlinear MPC of district heating networks*”, *European Control Conference (ECC)*, **2024**.