



Experts
en solutions
énergétiques
globales

groupe 

ÉCOSOLUTIONS SOUTERRAINES

District Heating Fribourg Thermal Energy Storage

HSLU TES Symposium

30 January 2026
Groupe E Celsius SA / ECCUS SA
Timothée Demierre / Téo Goddet

**CHAUFFAGE
À DISTANCE**
FRIBOURG



groupe e

CADFR Program

Key figures

2024



548 Buildings



23 MW Renewable



150 GWh



60 km of tubes



220 Projects

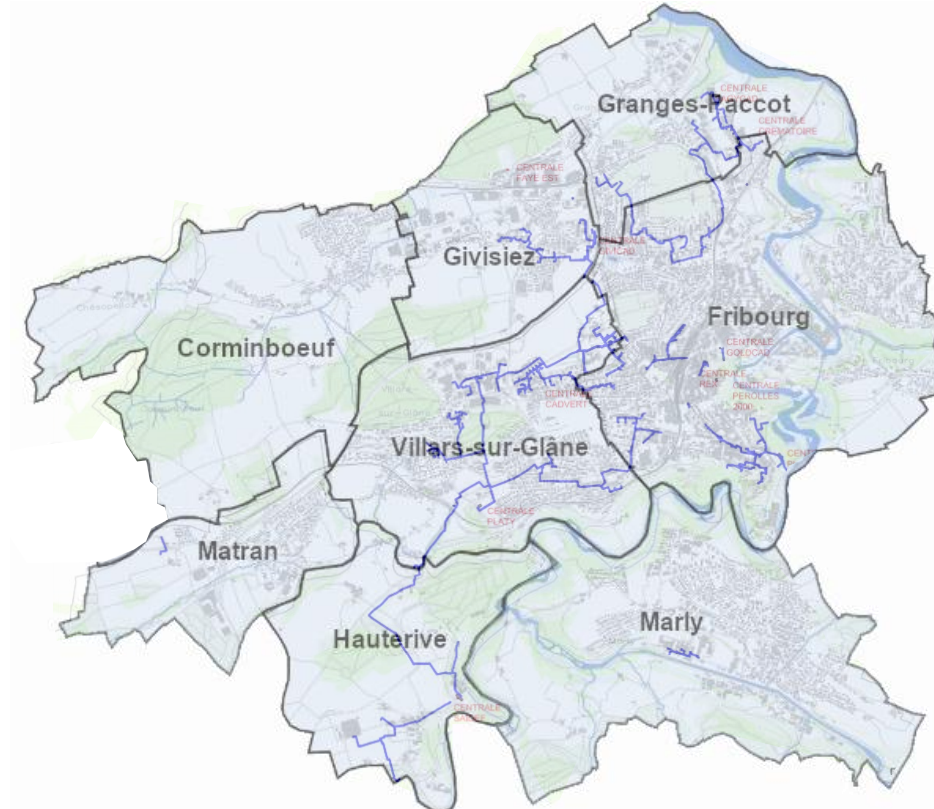

2050

~3000 Buildings

~150 MW Renewable

500-550 GWh

250 km of tubes



Why TES ?

Simulated use of the accumulator

Production & Power flows

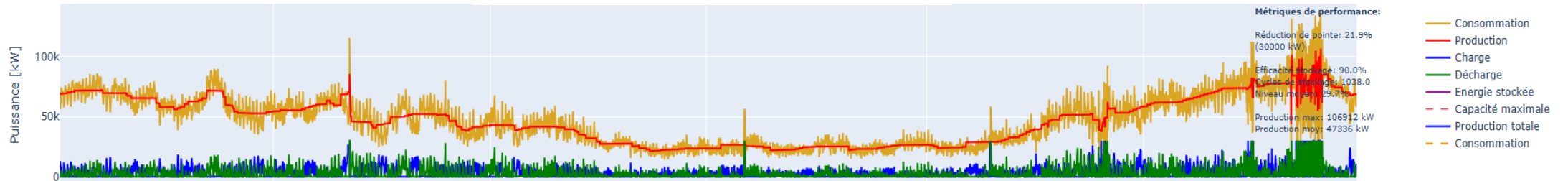

State of charge of the accumulator

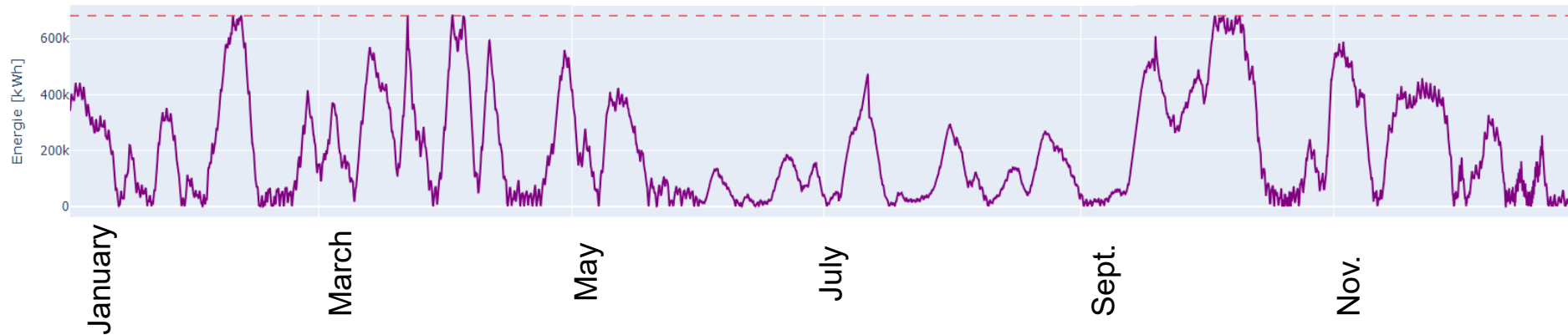

~12 equivalent full cycles of 600 MWh per year
Multiple time horizon (day, week & months)



Which TES technology ?

Qualitative analysis

After analysis of multiple TES solutions, **cavern storage is the best solution** for large scale storage, given the constraint of the region. This solution is **applicable in the whole Swiss Plateau**

		Environnemental			Network		Economics	
Storage Type		Environmental Impacts	Surfaces Requirements	Underground Requirements	Peak response	Storage Capacity	CAPEX	Maintenance
Tank Thermal Energy Storage	Tank	😊	😞	😊	😊	😐	😊	😐
Aquifer Thermal Energy Storage	Aquifer	😞	😊	😞	😐	😊	😐	😞
Pit Thermal Energy Storage	Pit	😊	😞	😐	😐	😐	😊	😐
Cavern Thermal Energy Storage	Cavern	😊	😊	😐	😐	😊	😐	😐
Borehole Thermal Energy Storage	Borehole	😐	😊	😐	😊	😐	😞	😊
Mine Thermal Energy Storage	Mine	😐	😊	😞	😐	😐	😐	😐
Underground Tank Thermal Energy Storage	Underground tank	😊	😐	😐	😊	😐	😞	😞



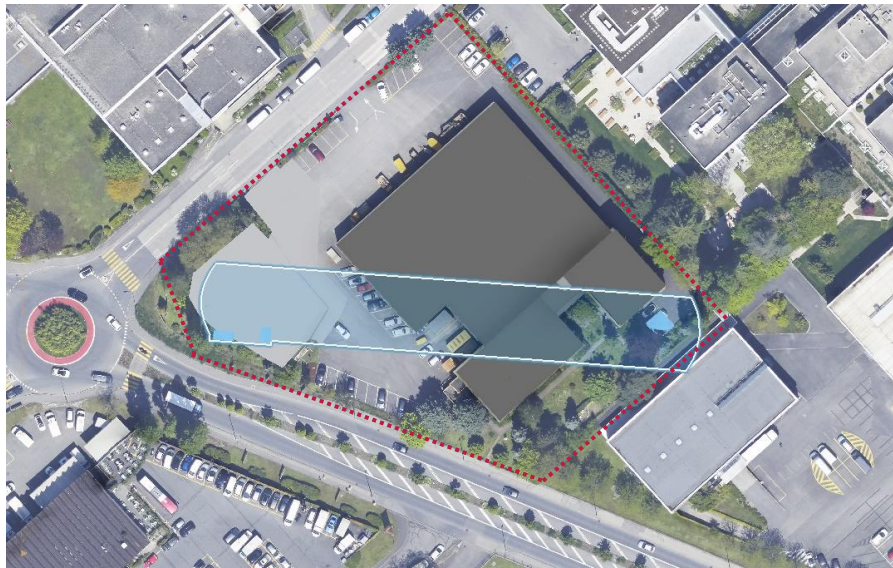

ECO-CAVERNE™

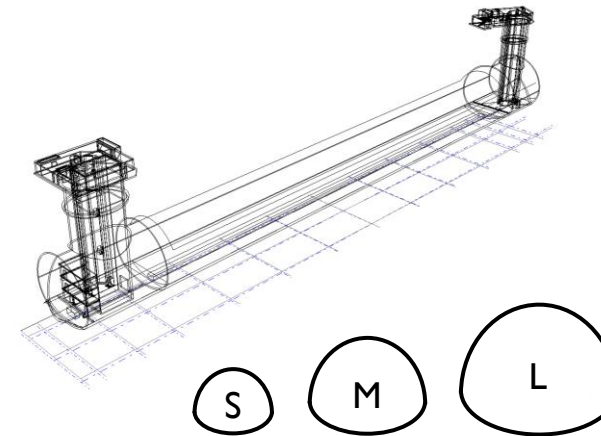

Off the shelf products



Turnkey delivery

-  Electrical supply
-  Fire protection
-  Atmosphere control
-  Shipping container access
-  Automation and supervision

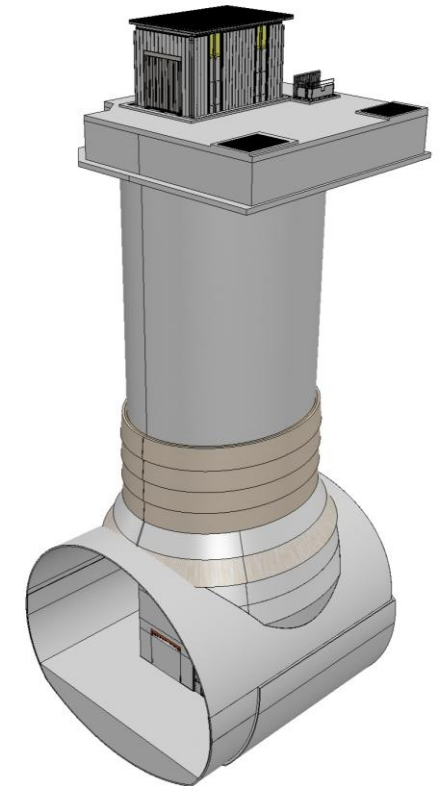

Datacenters



Robotic production



TARGET
DOMAINS



Battery Energy Storage



Long-term storage



Automated storage



Fruit conservation

Many industries may perfectly be operated underground



Building a Cavern TES



- Partnership with ECCUS SA
- ECCUS build the infrastructure, Groupe E the thermal process
- Specific design based on ECCUS standard design for ECO-Caverne
- Thin shell concrete structure built in the molassic rock

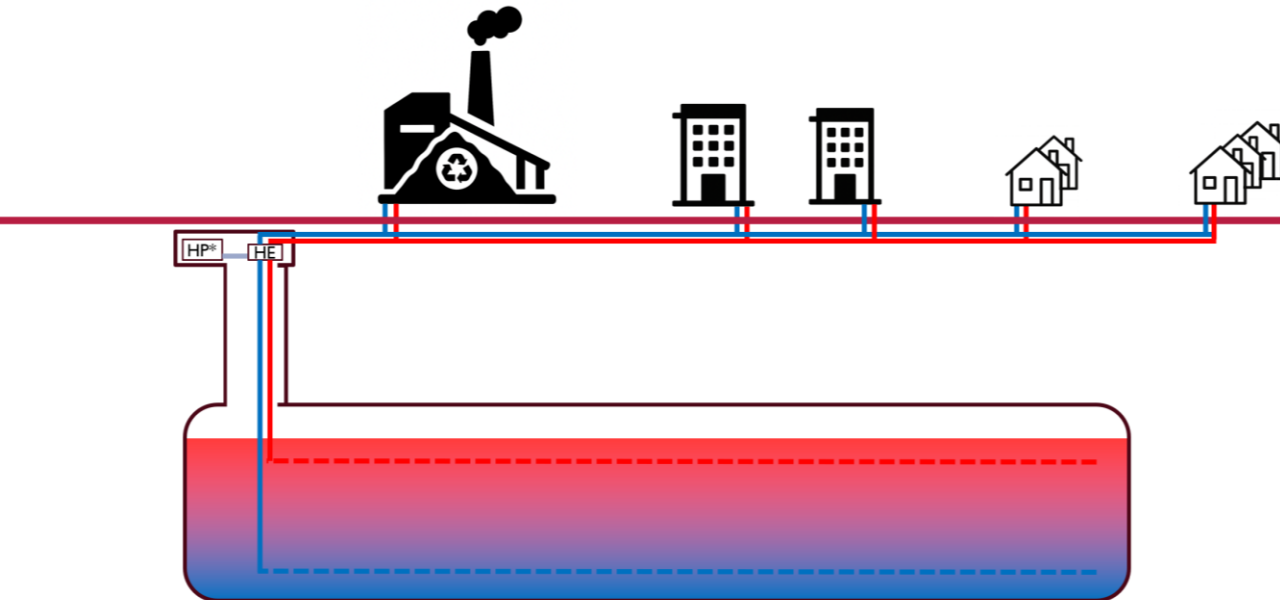



Economics

- Groupe E commit for 3 caverns of ~30'000 m³.
- Allows ECCUS to do the technical studies for the variant.

- Price range 300 to 500 CHF/m³

- Cost per stored kWh : 4 to 8 cts (based on 12 cycles of 600 MWh, 90% efficiency, 40y systems, 100y lifetime of the shell)



Conclusion

- Underground accumulators allows to switch constraints into opportunities
- Innovation is not always high tech
- Not rocket science but straightforward solution
- Get in touch to check applicability in your context



groupe 

ENSEMBLE POUR L'ÉNERGIE DE DEMAIN
TOGETHER FOR THE ENERGY OF TOMORROW